

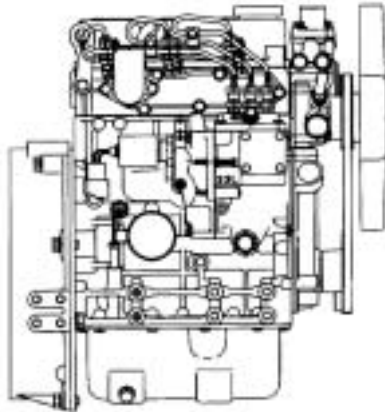

MITSUBISHI ENGINE

- *Since 1917 MITSUBISHI DIESEL engines have excelled worldwide.
- *Bred for durability and distinguished by reliability.
- *MITSUBISHI ranks among the world's largest diesel engine producers.
- *Full spectrum support service available from our own facility.
- *Application engineering and build-to-spec services available.



MITSUBISHI MHI small

8 to 128 Hp 2/3/4/6 cylinder

- Thirteen small mini diesels from 8 to 128 Hp in logical increments, in L, SL, SQ, SS, SK series engines.
- New next generation engines with advanced diesel technology.
- Very sociable, with smooth and balanced engine performance.
- Exceptionally low noise level from new High Efficiency combustion chambers.
- Same-side service points on all models.

MITSUBISHI MMC

100 Hp to 320 Hp

- Severe duty 6 cylinder diesels from Mitsubishi Motors Corp.
- Known for survivability and virtually fault free operation.
- Extremely easy service and maintenance procedures.
- Exceptionally well suited for extensive operating hours on prime duty gen sets and stationary duty.
- When you are serious about quality specify "MITSUBISHI MMC"

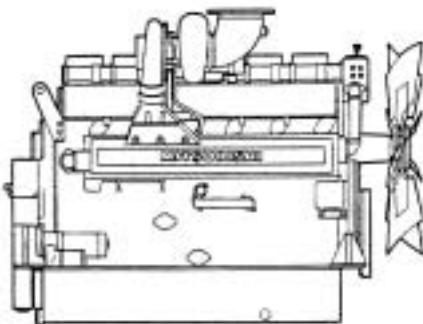
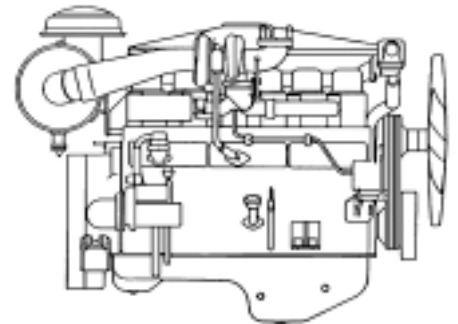

MITSUBISHI MHI large

300 to 2800 Hp 6/12/16 cylinder

- Premium quality diesel power for 1200, 1500, 1800 Rpm in the SB, SA, SR, and SH Series. (Sizes up to 54,000 Hp)
- Built in Sagami-hara factory that employs 41,115 people.
- Widely used by numerous prominent gen-set packagers in the USA.
- Service support contracts available.



Stauff Diesel Inc.
Stadco

Distributed by Stauffer Diesel Inc. Ephrata, PA 17522
email: mail@staufferdiesel.com
website: www.staufferdiesel.com

Home Office
P.O. Box 586
46 Pleasant Valley Road
Ephrata, Pa. 17522
Ph: 717-738-2500
Fax: 717-738-2550

Branch Office
(Pittsburgh Area)
55 Billot Avenue
Irwin, Pa. 15642
Ph: 724-864-6969
Fax: 724-864-9392

S90v02
rev. 5/02

MITSUBISHI DIESEL ENGINES

	MODEL	CYLINDER	DISPLACEMENT C. U. IN. (LITER)	CONTINUOUS (HP@RPM)	INTERMITTENT (HP@RPM)	GEN DRIVE HP@RPM (KWm)	APPROXIMATE DIMENSIONS			WEIGHT (LBS.)
							L	W	H	
MHI SMALL	L2E	2	38.7 (0.64)	13.3 @ 3600	14.8 @ 3600	14.8 @ 3600 (11.0)	17.6	17.6	20.6	135
	L3E	3	58 (0.95)	20.4 @ 3600	22.7 @ 3600	22.7 @ 3600 (16.9)	21.9	17.6	21.2	165
	S3L2	3	80.4 (1.32)	26.3 @ 3600	27.6 @ 3000	18.2 @ 1800 (13.6)	21.1	17.0	22.5	301
	S4L2	4	107 (1.76)	35 @ 3000	37 @ 3000	24.7 @ 1800 (18.4)	24.4	17.0	23.3	344
	S4Q2	4	152 (2.51)	44 @ 3000	47 @ 3000	35 @ 1800 (26.1)	27.8	20.0	25.0	430
	S4S	4	203 (3.33)	60 @ 2500	63 @ 2500	50 @ 1800 (37.0)	30.7	22.0	28.4	540
	S4SDT	4	203 (3.33)	67 @ 2500	74 @ 2500	64 @ 1800 (47.8)	30.7	22.0	32.0	551
	S4KT	4	259 (4.25)	71 @ 2200	79 @ 2200	79 @ 1800 (58.5)	35.5	25.0	37.0	772
	S6KT	6	388 (6.37)	103 @ 2200	115 @ 2200	128 @ 1800 (95.5)	46.0	25.0	38.5	1048
	MMC	6D14	6	400 (6.56)	110 @ 2500	121 @ 2500	102 @ 1800 (76.0)	47.0	28.0	33.0
6D14-T		6	400 (6.56)	142 @ 2500	157 @ 2500	153 @ 1800 (114.0)	47.0	28.0	36.0	1279
6D16-T		6	460 (7.55)	182 @ 2500	201 @ 2500	184 @ 1800 (137.0)	48.0	30.0	36.0	1312
6D24T		6	728 (11.95)	-	283 @ 2200	280 @ 1800 (209.0)	55.0	34.0	46.0	2227
6D24TC		6	728 (11.95)	-	319 @ 2200	298 @ 1800 (222.0)	55.0	35.0	48.0	2238
MHI LARGE		S6B-PTA	6	785 (12.88)	-	-	405 @ 1800 (302.0)	57.0	34.0	50.0
	S6B3-PTA	6	891 (14.60)	-	-	556 @ 1800 (415.0)	55.0	35.0	51.0	3410
	S6A3-PTA	6	1132 (18.56)	-	-	684 @ 1800 (510.0)	62.0	37.0	52.0	3938
	S6R-PTA	6	1495 (24.50)	-	-	878 @ 1800 (655.0)	67.0	41.0	59.0	5060
	S6R2-PTA	6	1828 (30.00)	-	-	717 @ 1200 (535.0)	67.0	42.0	62.0	5280
	S12A2-PTA	12	2070 (33.90)	-	-	1140 @ 1800 (850.0)	72.0	55.0	61.0	6424
	Mitsubishi engines available to 2800hp (2100KWm) mits.xls									